

CHERNG HORNG MACHINERY CO., LTD.

CLY-25LH

SEMI-AUTOMATIC SOFT LOOP HANDLE BAG MAKING MACHINE

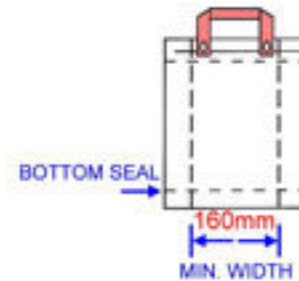

SPECIFICATION		
MODEL		CLY-25LH
Bag Size	Width (mm)	160 - 800
	Length (mm)	800
Size of Loop Handle (mm)		W: 30 L: 360
Thickness of Loop Handle -LDPE (mm)		0.18 - 0.25
Min. Bag Width without Gusset (mm)		250
Min. Bag Width with Gusset (mm)		160
Production Speed (Bag/min)		16
Power Required (KW)		2
Machine Dimension (M) (L x W x H)		1.5 x 1.8 x 1.3

* Specification subject to change without notice.

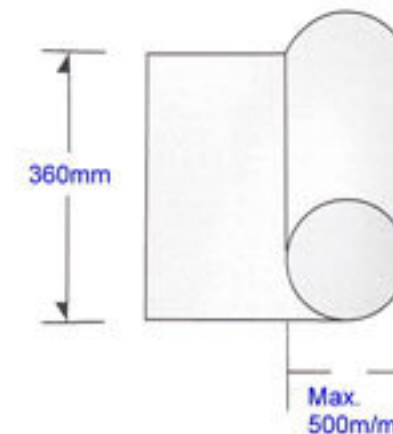
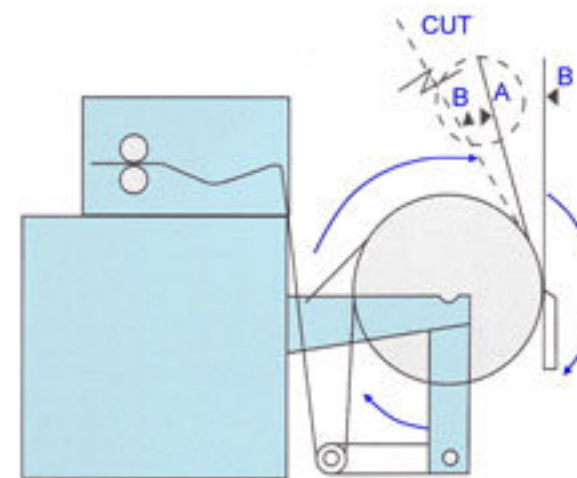

TWO SIDES OF THE PLASTIC FILM FOR LOOP HANDLE MUST BE SLIT ON BLOWN FILM MACHINE OR ON SLITTING MACHINE BEFORE PUTTING ON TO THE UNWIND STAND.

CHERNG HORNG MACHINERY CO., LTD.

TEL : +886-2-29811707, 29813178, 29829753

FAX : +886-2-29813455, 29817026

E-mail : extruder@ms8.hinet.net
extruderms8@yahoo.com.tw

Website : <http://www.extruder.com.tw>

CORONA TREATMENT : THE PLASTIC FILM FOR LOOP HANDLE MUST BE CORONA TREATED ON BLOWN FILM MACHINE.